

ITK 12-1
Water cooled triode

40 kW

- Output power:
40 kW in CW mode
- Anode voltage: 12 kV
- Anode dissipation: 15 kW
- Frequency up to 120 MHz

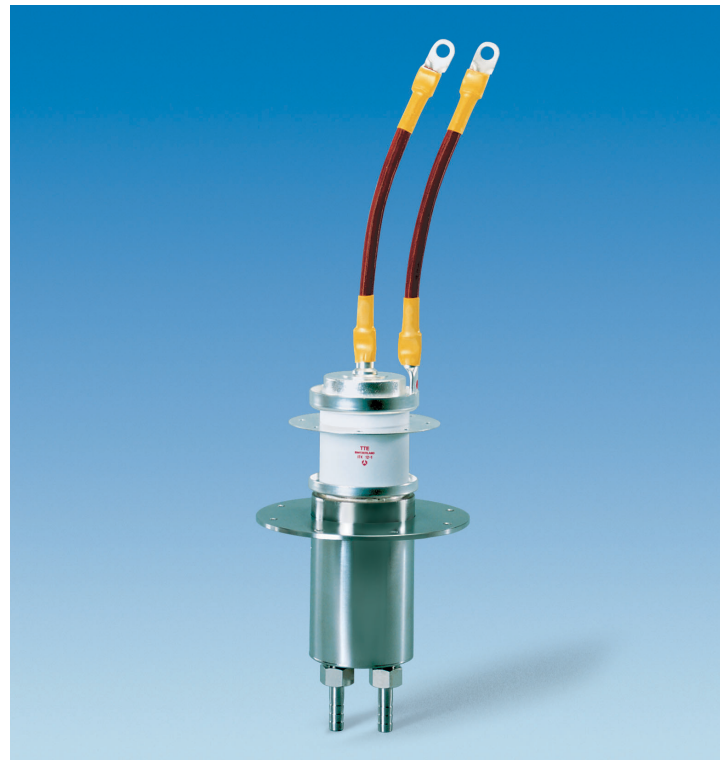



ITK 12-1

The ITK 12-1 is a RF power triode designed specifically for industrial applications.

This tube uses a coaxial design and metal-ceramic technology. This triode may be operated in CW or pulse modes.

For operation in pulse mode, the parameters depend on each equipment characteristics. Contact us for specific information.

The ITK 12-1 is a water cooled triode.

This product is designed, developed and manufactured at an ISO 9001 registered production site.

Electrical characteristics

Filament	thoriated tungsten		
Filament voltage (+ 5 %, - 10 %) (1)	5.8	V	
Filament current	145	A	
Surge current	600	A	max.
Cold resistance	5	mΩ	
Capacitances:			
• grid-anode	21	pF	
• grid-cathode	55	pF	
• cathode-anode (2)	1	pF	
Amplification factor	22		approx.
Transconductance (Va: 10 kV, Ia: 4 A)	50	mA/V	approx.

Mechanical characteristics

Operating position	vertical, anode up or down		
Weight	3.1	kg	approx.
Dimensions	see outline drawing		

Maximum ratings

Frequency (3)	120	MHz	
Anode voltage:			
• up to 30 MHz	12	kV	
• from 30 to 60 MHz	9	kV	
• from 60 to 90 MHz	7	kV	
• from 90 to 120 MHz	6	kV	
Control grid voltage	- 1 500	V	
Anode current	5.5	A	
Control grid current:			
• at full load	0.8	A	
• at no load	1.5	A	
Peak cathode current, CW	28	A	
Anode dissipation:			
• industrial cooling water	13	kW	
• distilled or deionized water	15	kW	
Grid dissipation:			
• up to 30 MHz	350	W	
• from 30 to 60 MHz	320	W	
• from 60 to 90 MHz	300	W	
• from 90 to 120 MHz	280	W	
Grid resistance (tube non conducting)	10	KΩ	

(1) At frequencies above 50 MHz, the filament voltage is reduced so that the ratio of filament voltage to current becomes the same as that without an anode voltage.

(2) Measured with a 40 x 40 cm shielding plate attached to the grid plate.

(3) Limited conditions above 30 MHz. Please consult Thales Electron Devices.

Cooling

Anode cooling	water		
Cooling water flow and pressure gradient	see cooling curves		
Temperature at outlet (industrial water)	60	°C	max.
Cooling water inlet pressure	5	bar	max.
Temperature at any point on tube envelope	220	°C	max.
Air flow on filament head	0.5	m ³ /min	

Typical operation (4)

Examples	Class C RF oscillator for industrial applications		
	1	2	
Frequency	30	30	MHz
Anode voltage	10	8	kV
Grid bias	- 650	- 560	V
Grid voltage	1 050	945	V
Anode current	5.3	4.8	A
Grid current, on load	0.69	0.76	A
Anode input power	53	38.4	kW
Anode output power	40	29	kW
Anode dissipation	12	8.6	kW
Grid dissipation	240	260	W
Grid resistance	1 000	740	Ω
Feedback ratio	11.7	13.1	%
Oscillator efficiency	75.5	76	%

(4) Operation with higher frequencies on request.

Cooling curves

Distilled, deionized or tap water may be used for cooling. The water flow rate and pressure drop required for a particular anode dissipation are indicated on the cooling curves.

Pa: anode dissipation
 Δp : pressure drop across the water cooler
 q: water flow rate
 T_{out} : outlet water temperature

(for an inlet water temperature of 20°C with industrial water and 50°C with distilled or deionized water).

**Industrial water -
 minimum resistivity: 5 kΩ.cm**

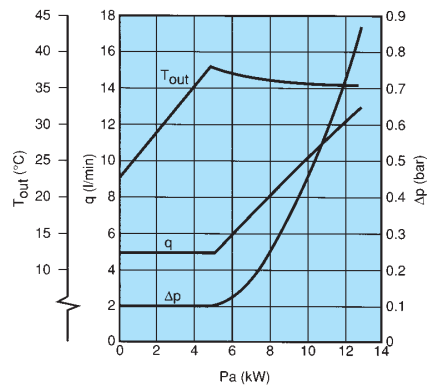

**Distilled or deionized water -
 minimum resistivity: 50 kΩ.cm**

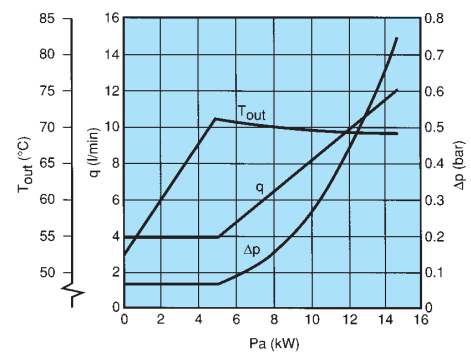

Constant current characteristics

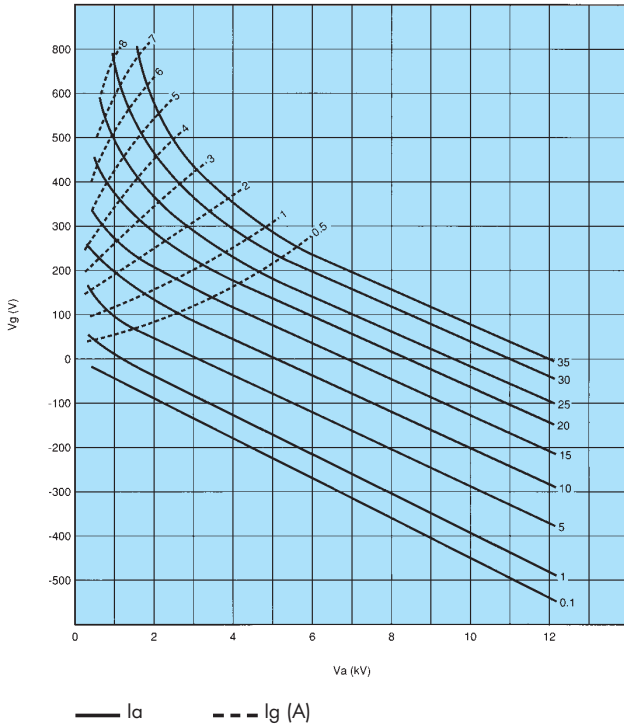

Outline drawing (dimensions in mm)

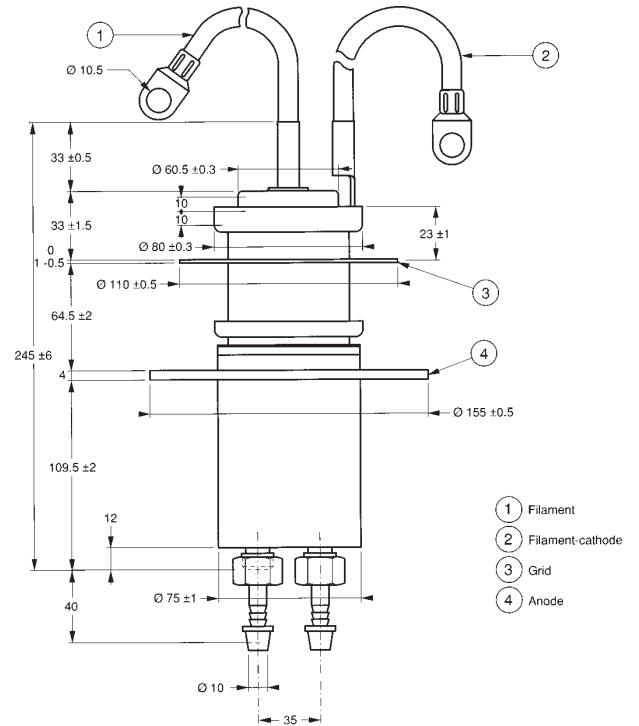

Top view (dimensions in mm)

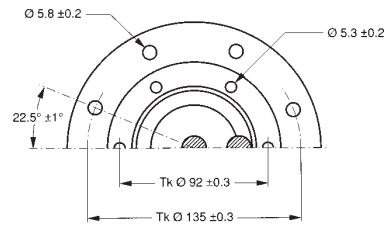

This document cannot be considered to be a contractual specification. The information given herein may be modified without notice due to product improvement or further development. Consult Thales Electron Devices before making use of this information for equipment design.

For further information, please contact:

THALES ELECTRON DEVICES

2 bis, rue Latécoère - 78941 Vélizy Cedex - France
 Tel: + 33 1 30 70 35 00 - Fax: + 33 1 30 70 35 35
www.thalesgroup.com/electronddevices