



## ITL 2-1

### Air-cooled triode for Industrial RF Heating



#### 5 kW triode for RF dielectric heating

Based on more than 60 years of experience in the design and manufacture of electron tubes, Thales is a long-standing partner to most producers of industrial heating machines. And we are the benchmark supplier of grid tubes.

The ITL 2-1 triode is intended for low power dielectric heating applications and delivers continuous RF power of 5 kW. It is especially well suited to industrial applications, such as plastic or agrifood dielectric heating.

This air-cooled triode uses a coaxial design and metal-ceramic technology. It may be operated in CW or pulse modes. For operation in pulse mode, the parameters depend on each equipment characteristics. Contact us for specific information.

Thales is fully committed to the long-term viability of tube technology, and to delivering high-tech products based on our proven expertise in complex processes. We offer the widest range on the market, whether for dielectric or induction and laser applications, backed by all the customer support and technical assistance services you need.

- Output power: 5 kW (CW mode)
- Anode voltage: 7.2 kV
- Anode dissipation: 1.5 kW
- Frequency up to 160 MHz

# ITL 2-1

## Industrial RF Heating triode

### Constant current characteristics

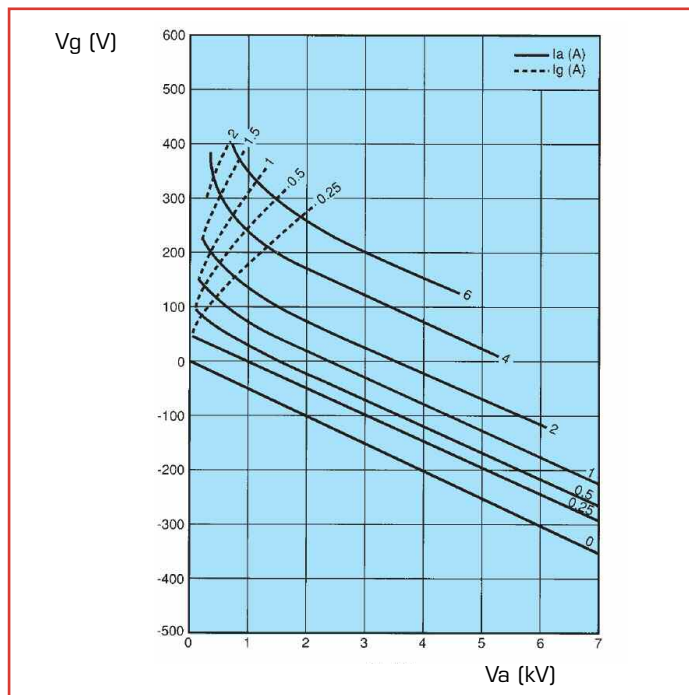

### Outline drawing (in mm)

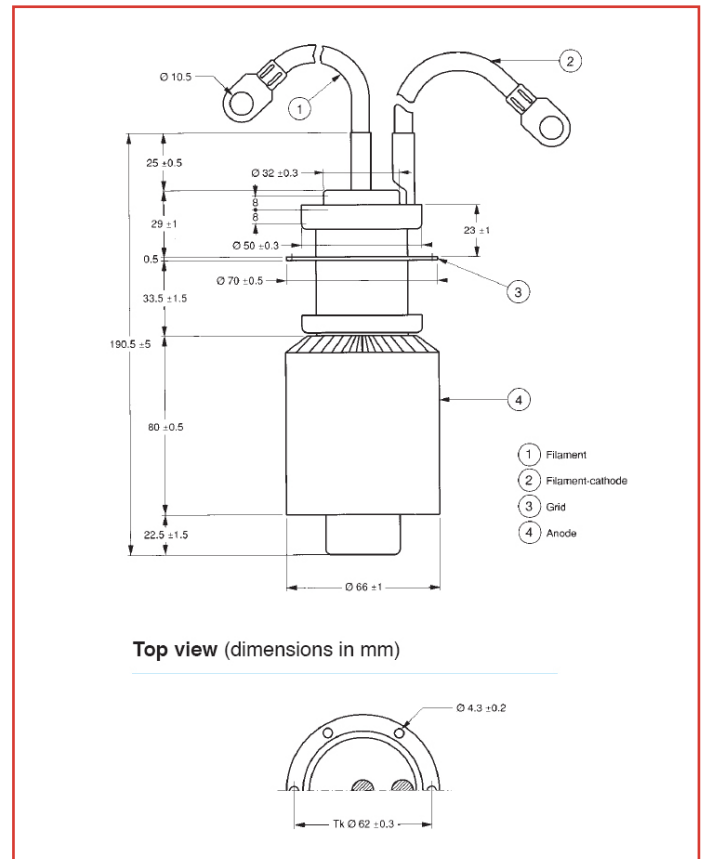

### Technical specifications

Cathode	thoriated tungsten
Filament voltage	6.3 V
Filament current	35 A
Max. heater surge current	125 A
Amplification factor	21
Capacitance	
• grid-anode	14 pF
• grid-cathode	17 pF
• cathode-anode	0.5 pF

### Mechanical characteristics

Operating position	vertical
Weight	1.1 kg
Dimensions	70 x 190.5 mm

### Cooling characteristics

Max. air temperature at tube inlet	45 °C
Min. air flow cooling (for $P_a=1.4$ kW)	1.5 m <sup>3</sup> /min
Corresponding air pressure cooling	3 mbar
Max. T° at any point on the tube envelop	220 °C

### Maximum ratings

Frequency	160 MHz
Anode voltage up to 85 MHz	7.2 kV
Anode voltage from 85 to 160 MHz	6 kV
Grid voltage	-1000 V
Anode current, CW	1.2 A
Grid current (up to 85 MHz), at full load, CW	0.28 A
Grid current, at no load, CW	0.40 A
Peak cathode current CW	7.5 A
Anode dissipation	1.5 kW
Grid dissipation up to 85 MHz	130 W
Grid dissipation from 85 to 160 MHz	100 W
Grid resistance (tube non conducting)	10 kΩ

### Class C, RF oscillator for industrial applications

Frequency	30 MHz
Anode voltage	5 kV
Anode current	1.1 A
Grid current, on load	0.24 A
Anode input power	6.6 kW
Anode output power	4.1 kW
Anode dissipation	1.5 kW
Grid dissipation	65 W
Grid resistance	1900 Ω
Feedback ratio	14.6 %
Oscillator efficiency	76 %

Operations at higher frequencies available on request.

For more technical information regarding this tube, feel free to ask our distributor Richardson Electronics - [www.rell.com](http://www.rell.com)

### THALES MICROWAVE & IMAGING SUB-SYSTEMS

2, rue Marcel Dassault - BP 23  
78141 Vélizy-Villacoublay Cedex - France

Phone: + 33 (0) 1 30 70 35 00  
Email: [rfs.marketing@thalesgroup.com](mailto:rfs.marketing@thalesgroup.com)

### RICHARDSON ELECTRONICS, Ltd

40W267 Keslinger Road  
LaFox, IL 60147-0393 - USA

Phone: +1 630 208 2200  
Email: [edg@rell.com](mailto:edg@rell.com)