

RS 3010 CJ

Water-cooled triode

11 kW

- Output power:
11 kW in CW mode
- Anode voltage: 7.2 kV
- Anode dissipation: 5 kW max.
- Frequency up to 150 MHz



THALES



RS 3010 CJ

The RS 3010 CJ is a RF power triode designed specifically for industrial applications. This tube uses a coaxial design and metal-ceramic technology. This triode is designed to operate in CW mode. For operation in pulse mode, the parameters depend on each

equipment characteristics, contact us for specific information.

The RS 3010 CJ is a water-cooled triode.

This product is designed, developed and manufactured at an ISO 9001 production site registered.

Electrical characteristics

| | | | |
|--|--------------------|------|---------|
| Filament | thoriated tungsten | | |
| Filament voltage (+ 5 %, - 10 %) | 6.3 | V | |
| Filament current | 66 | A | |
| Surge current | 198 | A | max. |
| Capacitance: | | | |
| • grid-anode | 14.5 | pF | |
| • grid-cathode | 19.5 | pF | |
| • cathode-anode (1) | 0.5 | pF | |
| Amplification factor | 20 | | approx. |
| Transconductance (Va: 2 kV, Ia: 0.5 A) | 22 | mA/V | approx. |

Mechanical Characteristics

| | | | |
|--------------------|----------------------------|----|---------|
| Operating position | vertical, anode up or down | | |
| Weight | 1.1 | kg | approx. |
| Dimensions | see outline drawing | | |

Maximum ratings

| | | | |
|------------------------------------|---------|-----|--|
| Frequency | 150 | MHz | |
| Anode voltage: | | | |
| • up to 85 MHz | 7.2 | kV | |
| • from 85 to 150 MHz | 6 | kV | |
| Control-grid voltage | - 1 000 | V | |
| Control-grid current (F < 85 MHz): | | | |
| • at full load, CW | 550 | mA | |
| • at no load, CW | 700 | mA | |
| Peak cathode current, CW | 12 | A | |
| Anode dissipation | 5 | kW | |
| Grid dissipation: | | | |
| • up to 85 MHz | 200 | W | |
| • from 85 to 150 MHz | 150 | W | |
| Grid resistance (at blocked tube) | 20 | kΩ | |

(1) Measured with a 30 cm diameter shielding plate in the grid terminal plane.

Cooling

| | | | |
|---|--------------------|--------------------|------|
| Anode cooling | water | | |
| Cooling water flow and pressure gradient | see cooling curves | | |
| Cooling water inlet pressure | 5 | bar | max. |
| Water inlet temperature | 35 | °C | max. |
| Temperature at any point on tube envelope | 220 | °C | max. |
| Air flow on tube terminal side | 0.5 | m ³ /mn | |

Typical operation (2)

Class C RF oscillator for industrial applications

| Examples | 1 | 2 | |
|--------------------------|-------|-------|-----|
| Frequency | < 85 | < 85 | MHz |
| Anode voltage | 6.5 | 6.5 | kV |
| Control grid bias | - 530 | - 550 | V |
| RF control grid voltage | 890 | 890 | V |
| Anode current | 2.25 | 2.03 | A |
| Control grid current | 535 | 500 | mA |
| Anode input power | 14.6 | 13.2 | kW |
| Anode output power (3) | 11 | 10 | kW |
| Anode dissipation | 3.3 | 2.7 | kW |
| Control grid dissipation | 160 | 145 | W |
| Grid resistance | 0.990 | 1.100 | kΩ |
| Feedback ratio | 15.3 | 15.1 | % |
| Oscillator efficiency | 75 | 76 | % |

(2) Operation with higher frequencies on request.

(3) Without taking circuit losses into account.

Nota: Data sheets are for information only. For design purpose, please ask for our latest specification.

Cooling water curves:

P_a : anode dissipation
 Δp : pressure drop
 q : water flow rate
 T_{out} : water outlet temperature

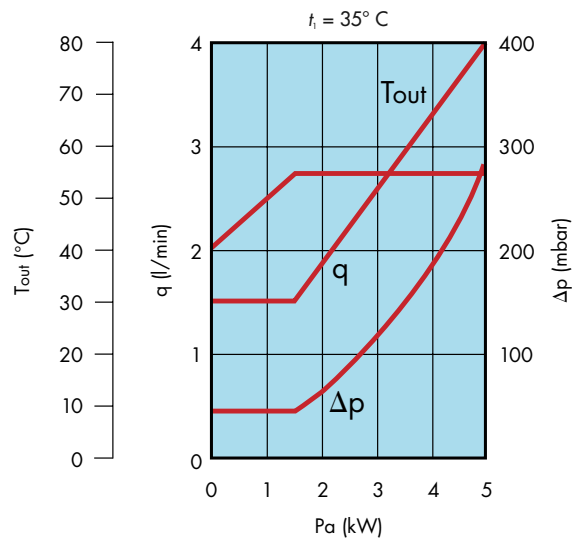

Constant current characteristics

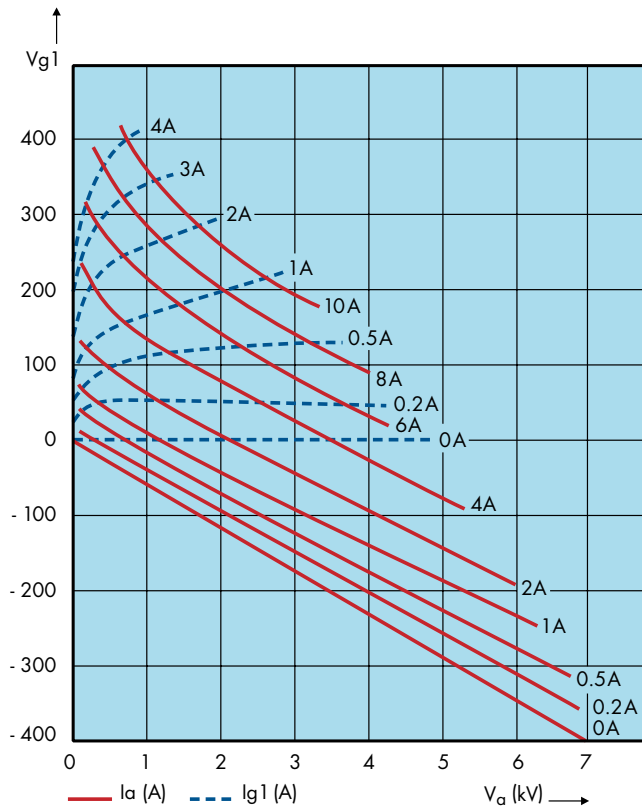

Outline drawing (mm)

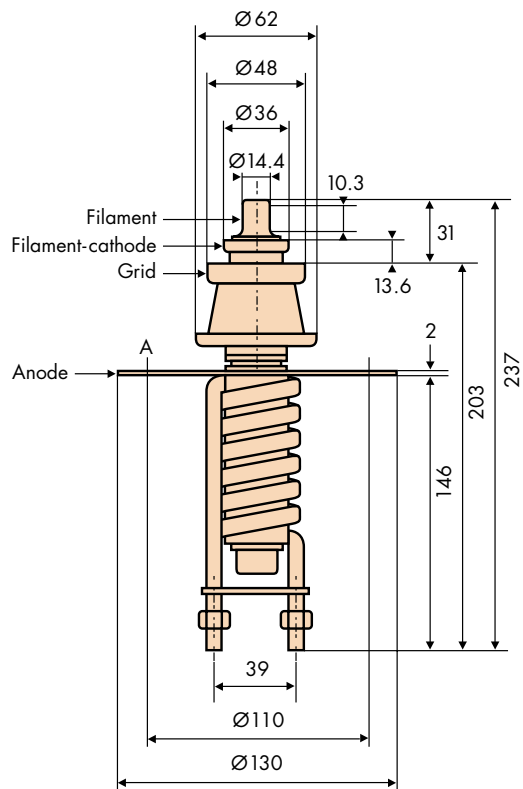

This document cannot be considered to be a contractual specification. The information given herein may be modified without notice due to product improvement or further development. Consult Thales Electron Devices before making use of this information for equipment design.

For further information, please contact:

THALES ELECTRON DEVICES

2 bis, rue Latécoère - 78941 Vélizy Cedex - France
 Tel: + 33 1 30 70 35 00 - Fax: + 33 1 30 70 35 35
www.thalesgroup.com/electronddevices