

# RS 3021 CJ

Water-cooled high- $\mu$  triode

**20 kW**

- Output power:  
20 kW in CW mode
- Anode voltage: 14 kV
- Anode dissipation: 20 kW max.
- Frequency up to 120 MHz



**THALES**



RS 3021 CJ

The RS 3021 CJ is a RF power high-amplification factor triode designed specifically for industrial applications. This tube uses a coaxial design and metal-ceramic technology. This triode is designed to operate in CW mode. For operation in pulse mode, the parameters

depend on each equipment characteristics, contact us for specific information. The RS 3021 CJ is a water-cooled triode.

This product is designed, developed and manufactured at an ISO 9001 production site registered.

### Electrical characteristics

Filament	thoriated tungsten		
Filament voltage (+ 5 %, - 10 %)	5.7	V	
Filament current	135	A	
Surge current	405	A	max.
Capacitance:			
• grid-anode	21.5	pF	
• grid-cathode	56	pF	
• cathode-anode (1)	0.3	pF	
Amplification factor	120		approx.
Transconductance (Va: 10 kV, Ia: 1.5 A)	50	mA/V	approx.

### Mechanical Characteristics

Operating position	vertical, anode up or down		
Weight	4.1	kg	approx.
Dimensions	see outline drawing		

### Maximum ratings

Frequency	120	MHz	
Anode voltage:			
• up to 40 MHz	14	kV	
• from 40 to 80 MHz	12	kV	
• from 80 to 120 MHz	10	kV	
Control-grid voltage	- 800	V	
Control-grid current (F < 40 MHz):			
• at full load, CW	1.7	A	
• at no load, CW	2.1	A	
Peak cathode current, CW	25	A	
Anode dissipation	20	kW	
Grid dissipation:			
• up to 40 MHz	500	W	
• from 40 to 80 MHz	420	W	
• from 80 to 120 MHz	330	W	
Grid resistance (at blocked tube)	15	kΩ	

(1) Measured with a 30 cm diameter shielding plate in the grid terminal plane.

## Cooling

Anode cooling	water		
Cooling water flow and pressure gradient	see cooling curves		
Cooling water inlet pressure	6	bar	max.
Water inlet temperature	35	°C	max.
Temperature at any point on tube envelope	220	°C	max.
Air flow on tube terminal side	0.7	m <sup>3</sup> /mn	

## Typical operation (2)

Examples	Class C RF oscillator for industrial applications		
	1	2	
Frequency	< 120	< 120	MHz
Anode voltage	10	7	kV
Control grid bias	- 290	- 200	V
RF control grid voltage	500	425	V
Anode current	2.5	2.73	A
Control grid current	0.9	1.2	A
Anode input power	25	19.1	kW
Anode output power (3)	20	15	kW
Anode dissipation	4.4	3.6	kW
Control grid dissipation	160	230	W
Grid resistance	325	170	Ω
Feedback ratio	5.4	6.5	%
Oscillator efficiency	80	78.5	%

(2) Operation with higher frequencies on request.

(3) Without taking circuit losses into account.

Nota: Data sheets are for information only. For design purpose, please ask for our latest specification.

## Cooling water curves:

$P_a$  : anode dissipation  
 $\Delta p$  : pressure drop  
 $q$  : water flow rate  
 $T_{out}$  : water outlet temperature

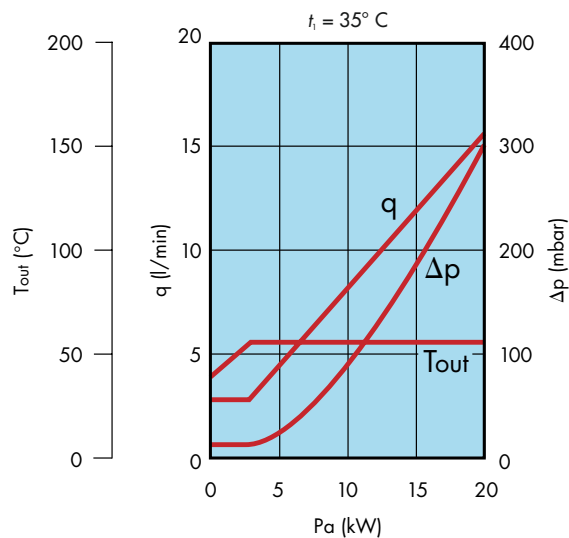

Constant current characteristics

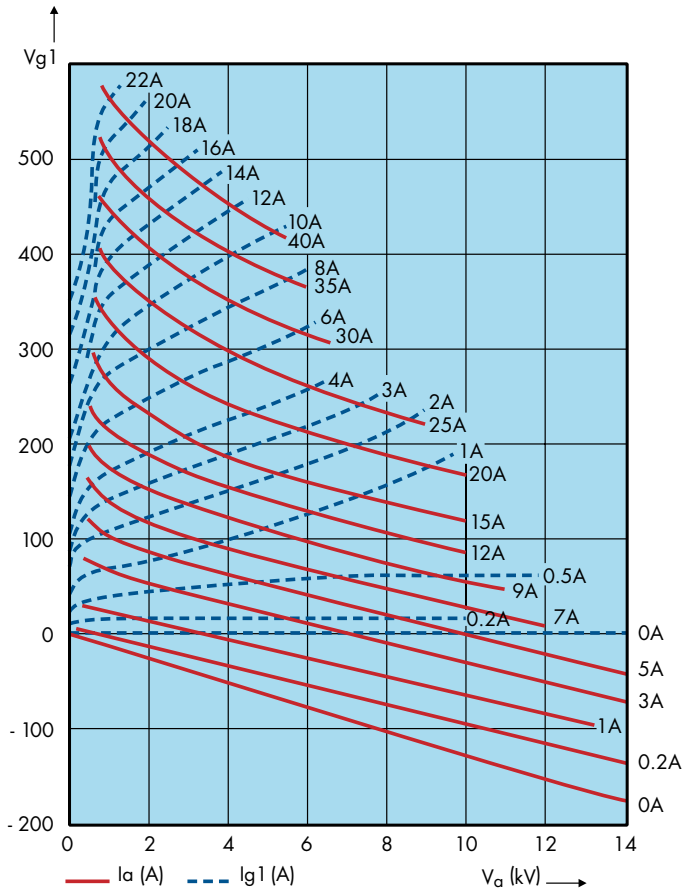

Outline drawing (mm)

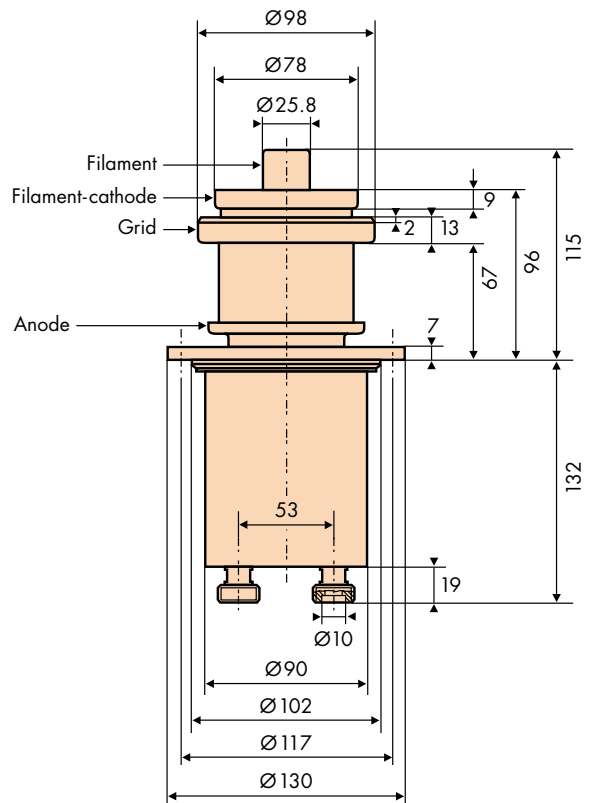

*This document cannot be considered to be a contractual specification. The information given herein may be modified without notice due to product improvement or further development. Consult Thales Electron Devices before making use of this information for equipment design.*

For further information, please contact:

## THALES ELECTRON DEVICES

2 bis, rue Latécoère - 78941 Vélizy Cedex - France  
 Tel: + 33 1 30 70 35 00 - Fax: + 33 1 30 70 35 35  
[www.thalesgroup.com/electrondevices](http://www.thalesgroup.com/electrondevices)