



## RS 3027 CJ

High- $\mu$ , water-cooled triode for Industrial RF Heating



- Output power: 32 kW (CW mode)
- Anode voltage: 14 kV
- Anode dissipation: 25 kW
- Frequency up to 120 MHz

### 32 kW triode for RF induction heating machines

Based on more than 60 years of experience in the design and manufacture of electron tubes, Thales is a long-standing partner to most producers of industrial heating machines. And we are the benchmark supplier of grid tubes.

The RS 3027 CJ triode, intended for induction dielectric heating applications, delivers continuous RF power of 32 kW. It is especially well suited to industrial applications such as the heat treatment of metals.

This water-cooled triode uses a coaxial design and metal-ceramic technology. It may be operated in CW or pulse modes. For operation in pulse mode, the parameters depend on each equipment characteristics. Contact us for specific information.

Thales is fully committed to the long-term viability of tube technology, and to delivering high-tech products based on our proven expertise in complex processes. We offer the widest range on the market, whether for dielectric or induction and laser applications, backed by all the customer support and technical assistance services you need.

# RS 3027 CJ

## Industrial RF Heating

### Constant current characteristics

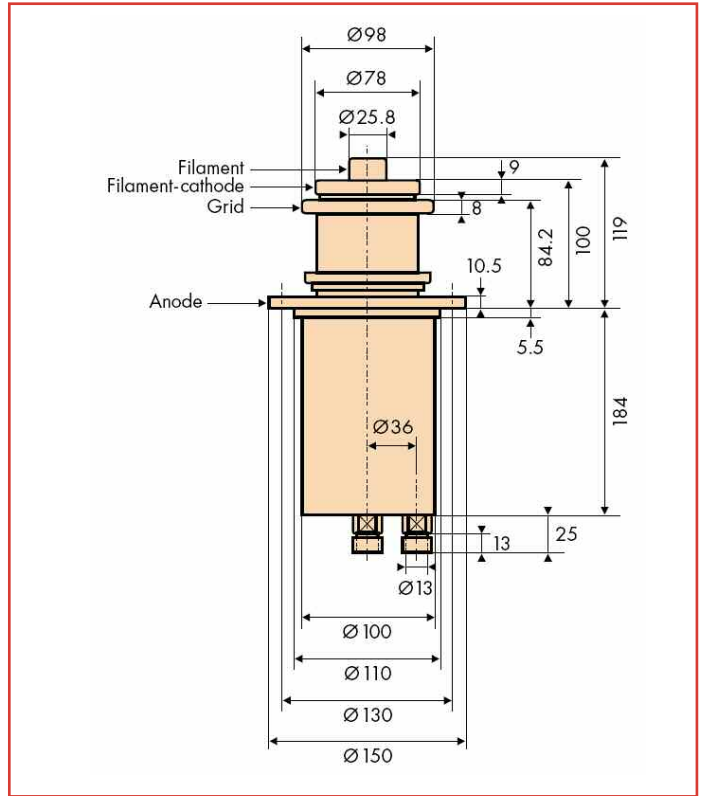
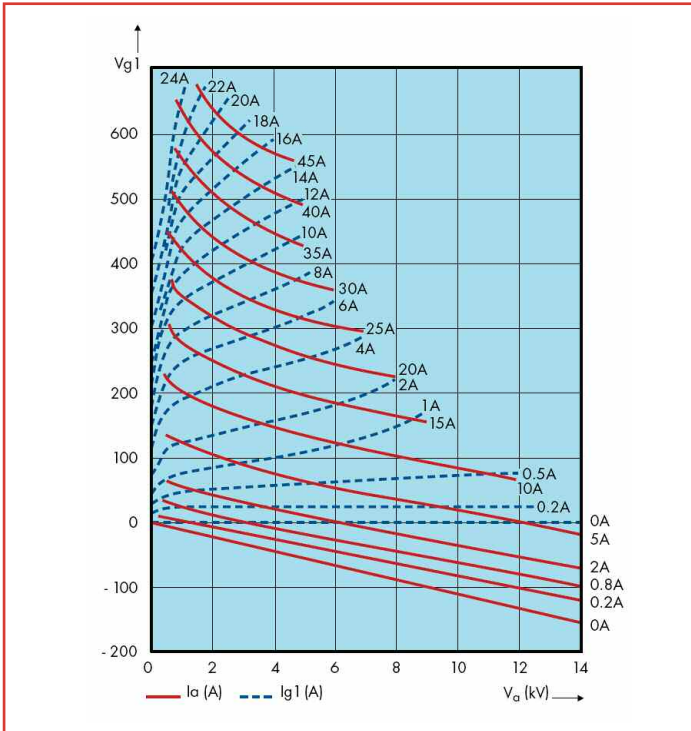

### Technical specifications

Cathode	thoriated tungsten
Filament voltage	7 V
Filament current	115 A
Max. heater surge current	345 A
Amplification factor	100
Capacitance	
• grid-anode	26 pF
• grid-cathode	65 pF
• cathode-anode	0.7 pF

### Mechanical characteristics

Operating position	vertical
Weight	7 kg
Dimensions	130 x 303 mm

### Cooling characteristics (industrial water)

Max. water temperature at tube outlet	50 °C
Min. water pressure at tube inlet	6 bar
Max. T° at any point on the tube envelop	220 °C
Min. air flow on filament connections	0.7 m <sup>3</sup> /min

### Maximum ratings

Frequency	120	MHz
Anode voltage		
• up to 40 MHz	14	kV
• from 40 to 80 MHz	12	kV
• from 80 to 120 MHz	10	kV
Grid voltage	-800	V
Grid current, at full load up to 40 MHz	2.3	A
Grid current, off load up to 40 MHz	2.8	A
Cathode current CW	6	A
Anode dissipation	25	kW
Grid dissipation		
• up to 40 MHz	1000	W
• from 40 to 80 MHz	800	W
• from 80 to 120 MHz	600	W
Grid resistance	12	k $\Omega$

### Class C, RF oscillator for industrial applications

Frequency	<120	<120	MHz
Anode voltage	10	8	kV
Anode current	4.15	3.90	A
Anode input power	41.5	31.5	kW
Anode output power	32	24	kW
Anode dissipation	8.7	6.6	kW
Grid current, on load	1.5	1.6	A
Grid dissipation	400	420	W
Grid resistance	185	162	$\Omega$
Feedback ratio	6.6	7.9	%
Oscillator efficiency	77	76	%

Operations at higher frequencies available on request.

For more technical information regarding this tube, feel free to ask our distributor Richardson Electronics - [www.rell.com](http://www.rell.com)

### THALES MICROWAVE & IMAGING SUB-SYSTEMS

2, rue Marcel Dassault - BP 23  
78141 Vélizy-Villacoublay Cedex - France

Phone: + 33 (0) 1 30 70 35 00  
Email: [rfms.marketing@thalesgroup.com](mailto:rfms.marketing@thalesgroup.com)

### RICHARDSON ELECTRONICS, Ltd

40W267 Keslinger Road  
LaFox, IL 60147-0393 - USA

Phone: +1 630 208 2200  
Email: [edg@rell.com](mailto:edg@rell.com)