



RS 3040 CJ

Water-cooled triode for Industrial RF Heating



- Output power: 60 kW (CW mode)
- Anode voltage: 14 kV
- Anode dissipation: 32 kW
- Frequency up to 100 MHz

60 kW triode for RF dielectric heating machines

Based on more than 60 years of experience in the design and manufacture of electron tubes, Thales is a long-standing partner to most producers of industrial heating machines. And we are the benchmark supplier of grid tubes.

The RS 3040 CJ triode, intended for dielectric heating applications, delivers continuous RF power of 60 kW. It is especially well suited to industrial applications such as textile, food and paper drying.

This water-cooled triode uses a coaxial design and metal-ceramic technology. It may be operated in CW or pulse modes. For operation in pulse mode, the parameters depend on each equipment characteristics. Contact us for specific information.

Thales is fully committed to the long-term viability of tube technology, and to delivering high-tech products based on our proven expertise in complex processes. We offer the widest range on the market, whether for dielectric or induction and laser applications, backed by all the customer support and technical assistance services you need.

RS 3040 CJ

Industrial RF Heating

Constant current characteristics

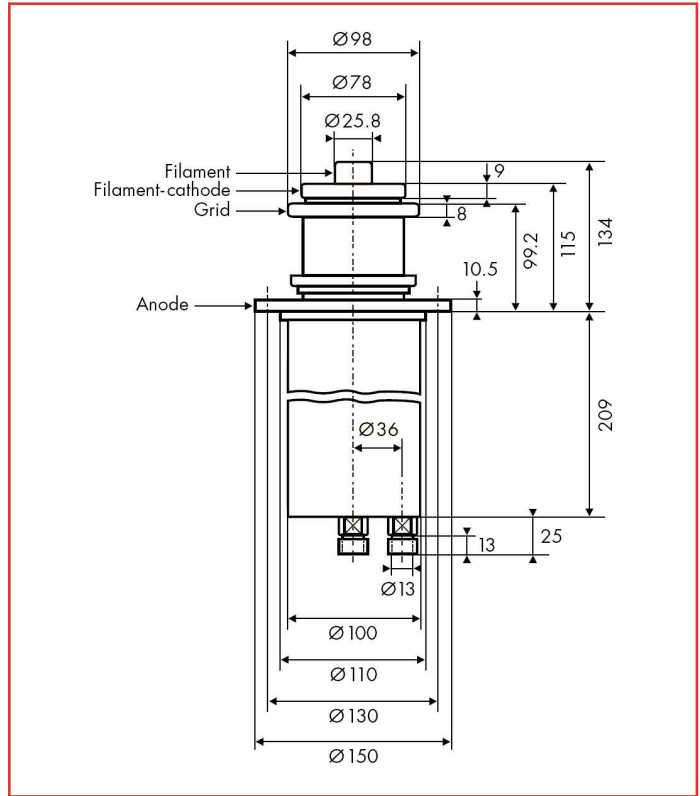
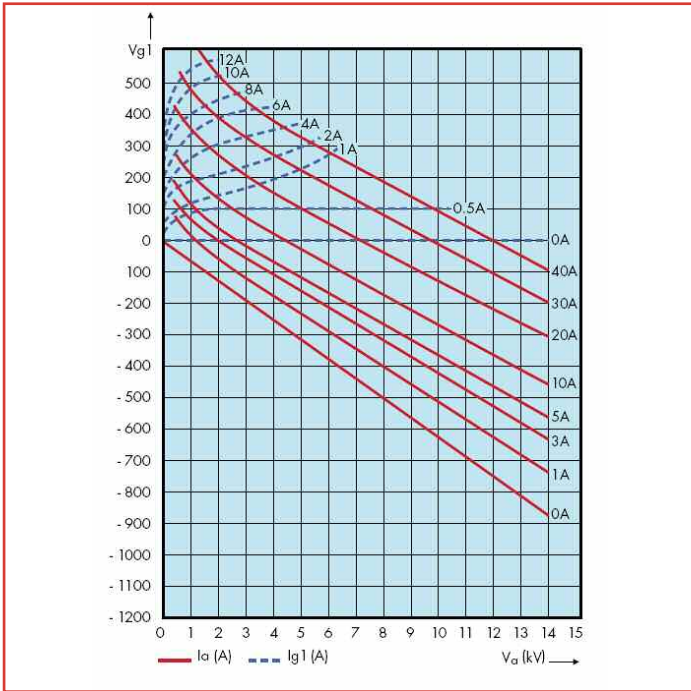

Technical specifications

Cathode	thoriated tungsten
Filament voltage	8 V
Filament current	185 A
Max. heater surge current	560 A
Amplification factor	20
Capacitance	
• grid-anode	29 pF
• grid-cathode	78 pF
• cathode-anode	2 pF

Mechanical characteristics

Operating position	vertical
Weight	8.5 kg
Dimensions	150 x 368 mm

Cooling characteristics (industrial water)

Max. water temperature at tube outlet	55 °C
Min. water pressure at tube inlet	6 bar
Max. T° at any point on the tube envelop	220 °C
Min. air flow on filament connections	1 m ³ /min

Maximum ratings

Frequency	120	MHz
Anode voltage		
• up to 30 MHz	14	kV
• from 30 to 50 MHz	10	kV
• from 50 to 100 MHz	7.5	kV
Grid voltage	-1500	V
Grid current, at full load up to 30 MHz	1.6	A
Grid current, off load up to 30 MHz	1.9	A
Cathode current	12	A
Anode dissipation	35	kW
Grid dissipation		
• up to 30 MHz	820	W
• from 30 to 50 MHz	700	W
• from 50 to 100 MHz	600	W
Grid resistance	12	k Ω

Class C, RF oscillator for industrial applications

Frequency	<30	<30	MHz
Anode voltage	12	12	kV
Anode current	6.3	5.2	A
Anode input power	76	62.4	kW
Anode output power	60	50	kW
Anode dissipation	14	11	kW
Grid current, on load	1.2	1	A
Grid dissipation	470	350	W
Grid resistance	920	1000	Ω
Feedback ratio	14.5	12.7	%
Oscillator efficiency	79	80	%

Operations at higher frequencies available on request.

For more technical information regarding this tube, feel free to ask our distributor Richardson Electronics - www.rell.com

THALES MICROWAVE & IMAGING SUB-SYSTEMS

2, rue Marcel Dassault - BP 23
78141 Vélizy-Villacoublay Cedex - France

Phone: + 33 (0) 1 30 70 35 00
Email: rfms.marketing@thalesgroup.com

RICHARDSON ELECTRONICS, Ltd

40W267 Keslinger Road
LaFox, IL 60147-0393 - USA

Phone: +1 630 208 2200
Email: edg@rell.com